

REINHOLD ENVIRONMENTAL Ltd.



2011 APC Round Table & Expo Presentation

July 11-12, 2011, in Cleveland, OH / Hosted by FirstEnergy

All presentations posted on this website are copyrighted by Reinhold Environmental, Ltd (RE). Any unauthorized downloading, attempts to modify or to incorporate into other presentations, link to other websites, or obtain copies for any other uses than the training of attendees to RE's Conferences is expressly prohibited, unless approved in writing by RE or the original presenter. RE does not assume any liability for the accuracy or contents of any materials contained in this library which were presented and/or created by persons who were not employees of RE.



**Electrostatic Precipitator Operations
Trapped Key Interlocks
July 11, 2011
Sean McGuinness**



Topics

- Trapped Key Interlock Systems
- What is a Trapped Key interlock?
- Why interlock an Electrostatic Precipitator?
- How do interlocks operate?
- Where are interlocks used on the ESP
- Typical ESP interlock schemes
- Common interlock styles
- Question & Answers



What is an Interlock?

- An interlock is a safety device applied to two or more moveable parts, preventing or allowing operation of one part, only when another part is locked in a pre-determined position.

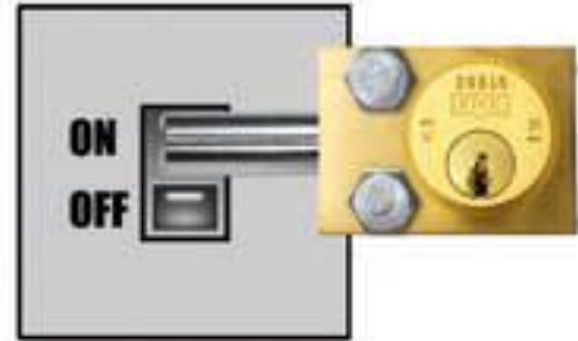
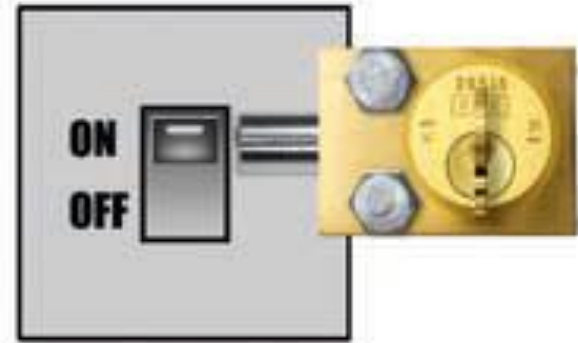

Key Interlock Types

- Pin & Tumbler: Mostly made out of brass
 - Use “House Style Key”



- Dowel & Pin: Brass and Stainless Steel versions
 - Use bulkier style key
 - Gasket



- Letter or Figure style: Brass and Stainless Steel versions
 - Use bulkier style key
 - Gasket



Why Interlock an ESP?

- Preserve safety in your sequential operations
- Eliminate access to energized or charged equipment
- Prevent improper grounding of T/R's
- Avoid exposure to nuclear source detectors



How do Interlocks Operate?

- Interlocks operate on the principle that the key can be removed only when the locking bolt is in a predetermined position, thereby indicating that the equipment is in a predetermined state.

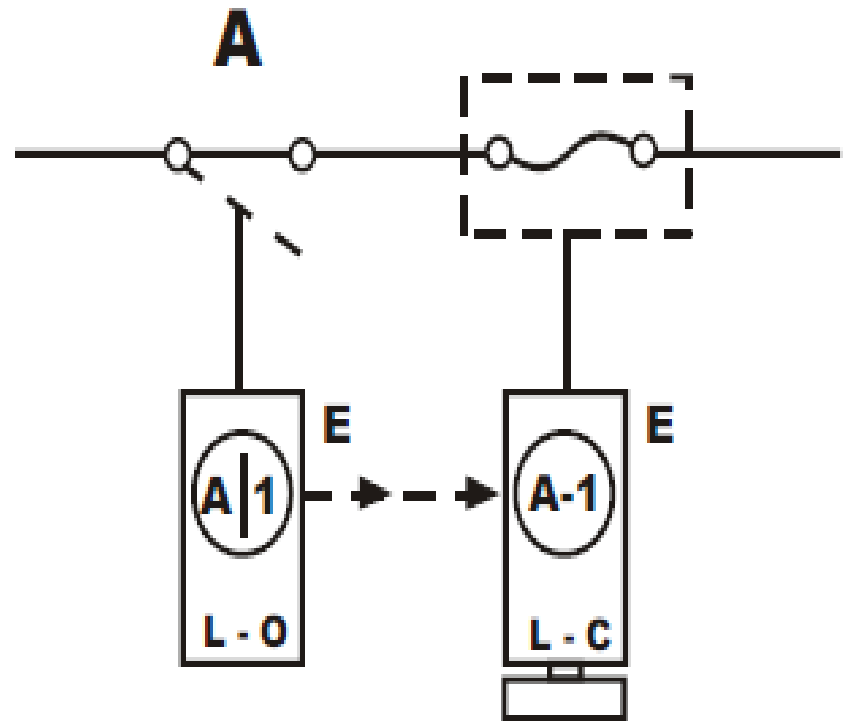

Where are Interlocks Used on the ESP

- Power Feed to ESP (Breaker, MCC, AVC)
- Transformer Rectifier Ground Switch (T/R)
 - Dual Bushing Splitter Switch
- Nuclear Level Detectors
- Key Exchange Boxes
- Doors – Side, Duct, Roof, Insulator, Coffin, Penthouse, etc.



Manufacturer's Interlock Provisions

- ESP Equipment
 - Power Control Equipment
 - Transformer Rectifier
 - Doors
- To lock ON or OFF
- If no mounting provision ask interlock supplier.



T/R and ESP OEM's Mounting Provisions

- New ESP or Aftermarket
- All T/R and ESP Models
 - NWL
 - Stock
 - Stein
 - B&W
 - Buell
 - Lodge Cottrell FLSmith-Airtech
 - GE
 - Joy
 - Hamon
 - Siemens Wheelabrator
 - AirTek (Environmental Elements)
 - Southern Environmental
 - Alstom
- Key Interlocks are also used on a Baghouse



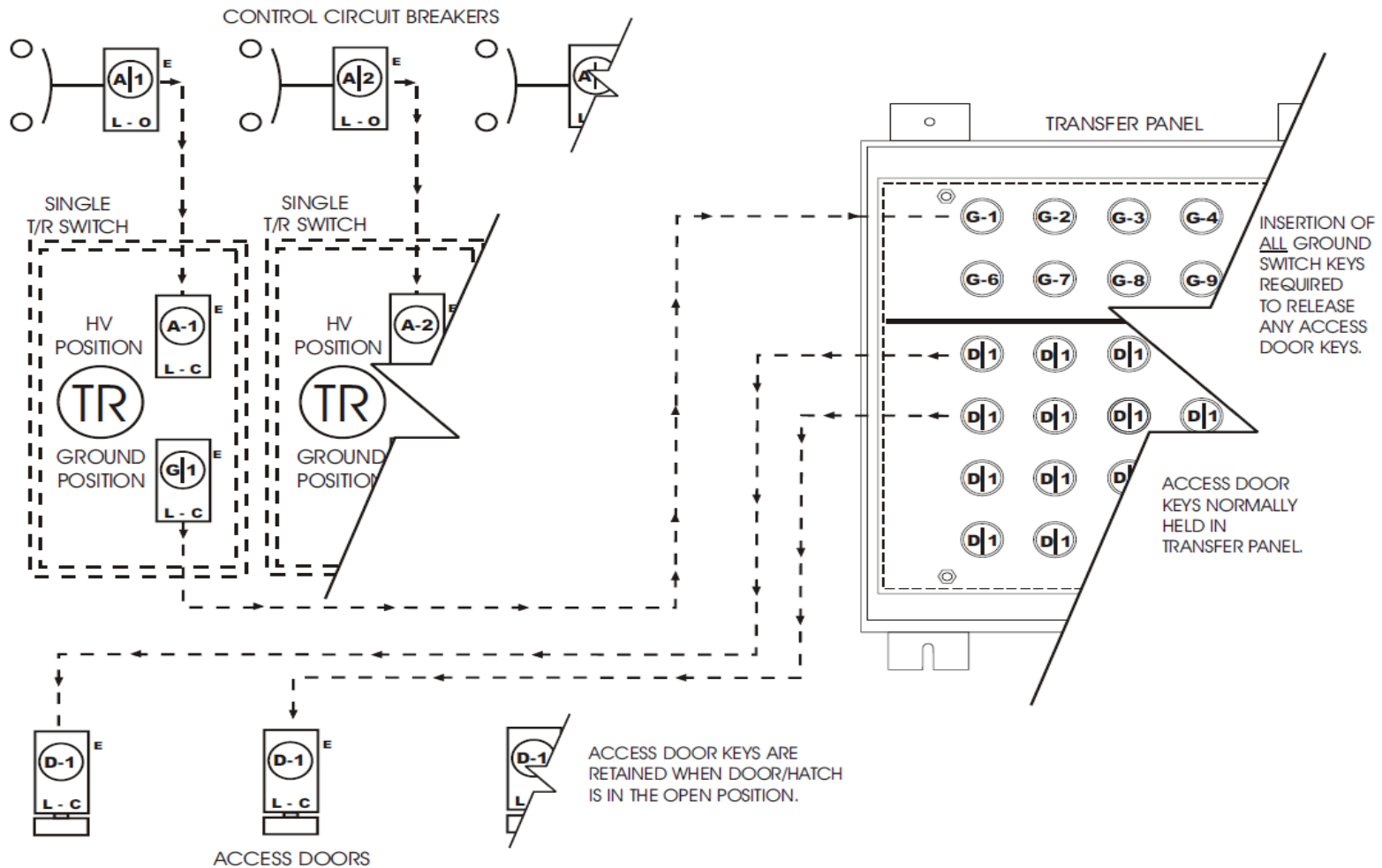

Precipitator scheme with single output transformer rectifiers.

Advantages

- Similar to “lock-out” ...fix mounted
- Trapped Key allows for integration of a shut-down procedure into the design of an ESP
- Sequential Key exchange forces a safe condition before access is permitted to any potentially hazardous area
- Avoids incorrect shut-down
- Eliminates operator error
- Reduces downtime



Power Feed Interlocks

- Circuit Breakers, AVC, MCC



Transformer Rectifier

- T/R Ground Switch



T/R Ground with Splitter



T/R Application

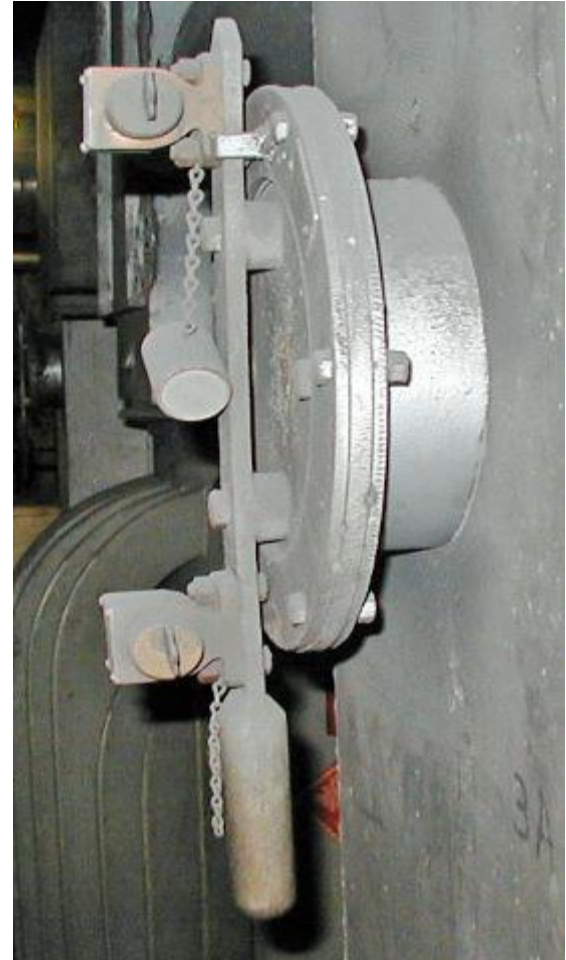

Key Exchange Panel

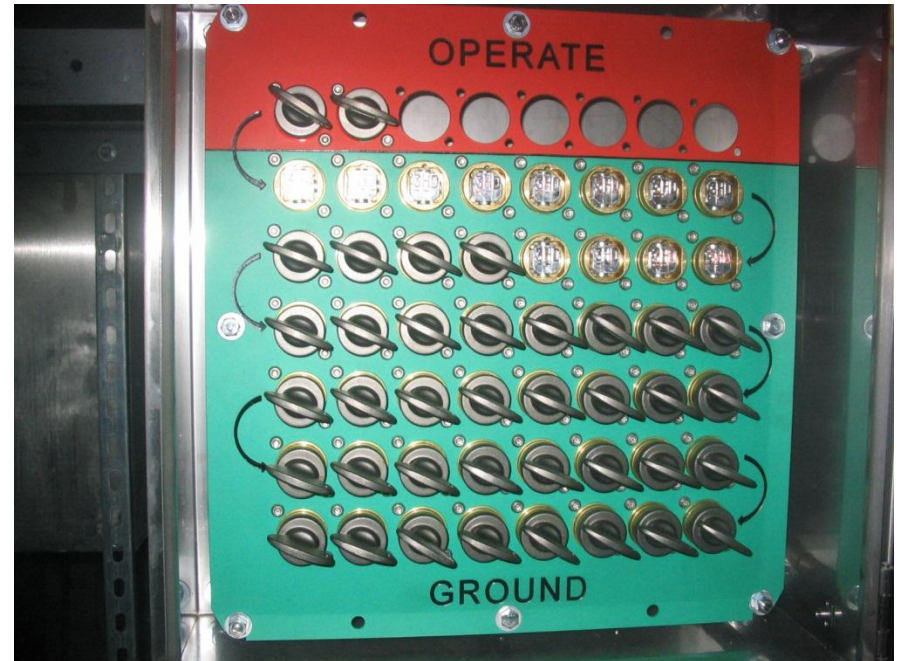

Level Detectors



Door Interlocks





ESP with Single Output T/R's

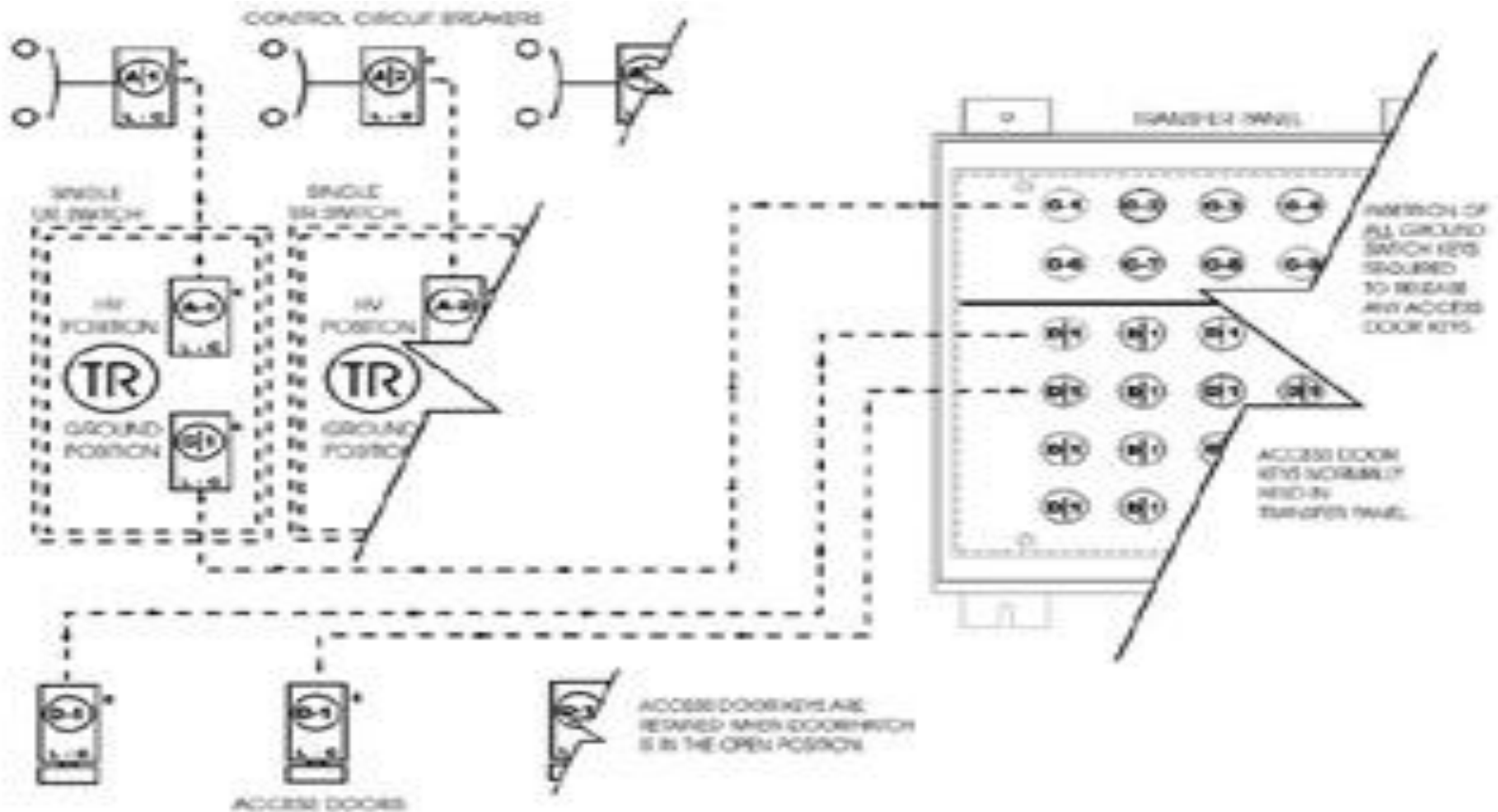

Rectifier scheme with single output transformer rectifiers.

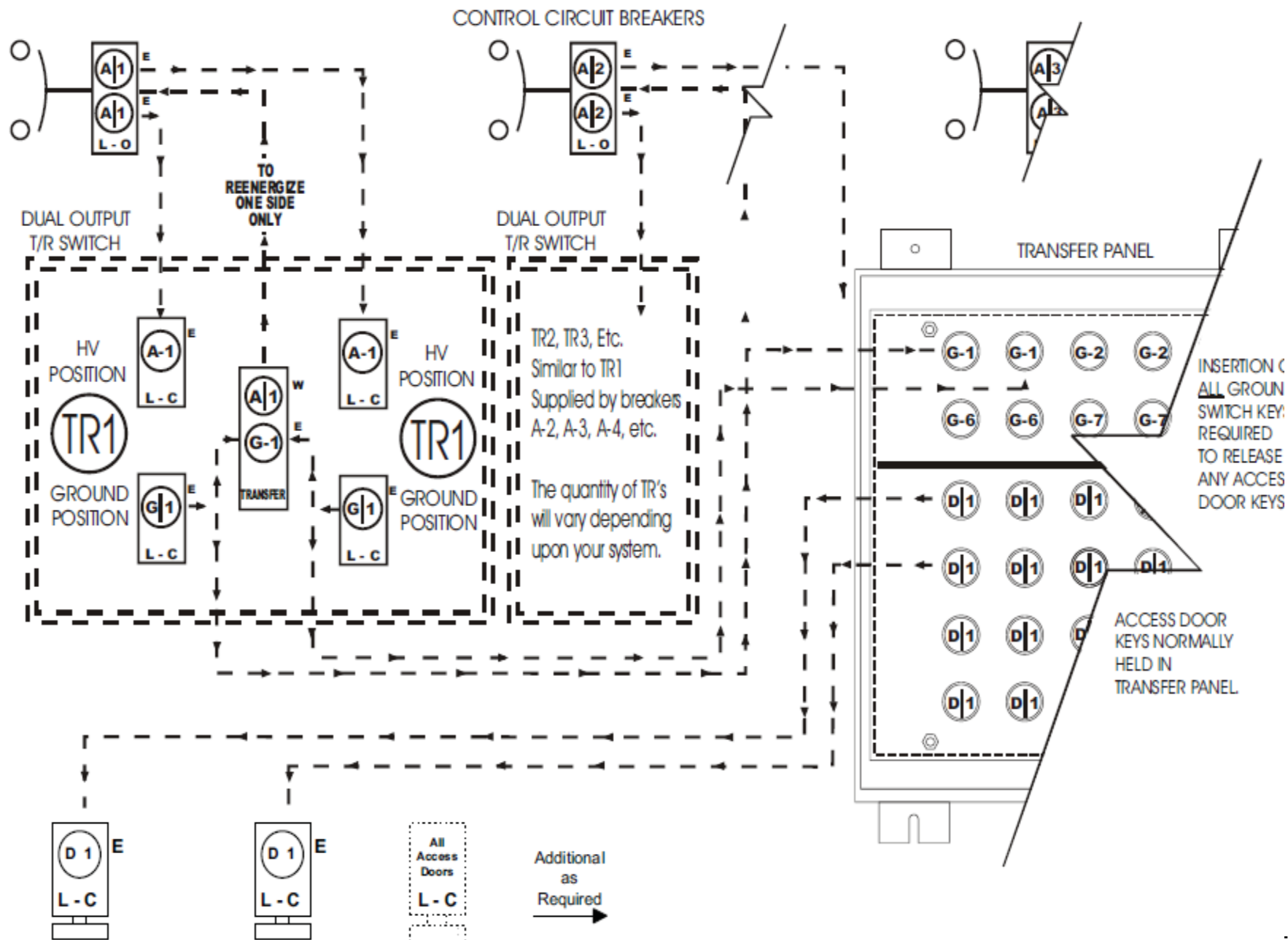

All ESP Access Doors, Hopper Doors, Etc.

ACCESS DOOR KEYS ARE RETAINED WHEN DOOR/HATCH IS IN THE OPEN POSITION.

Scheme 42B ESP with Dual Output T/R's

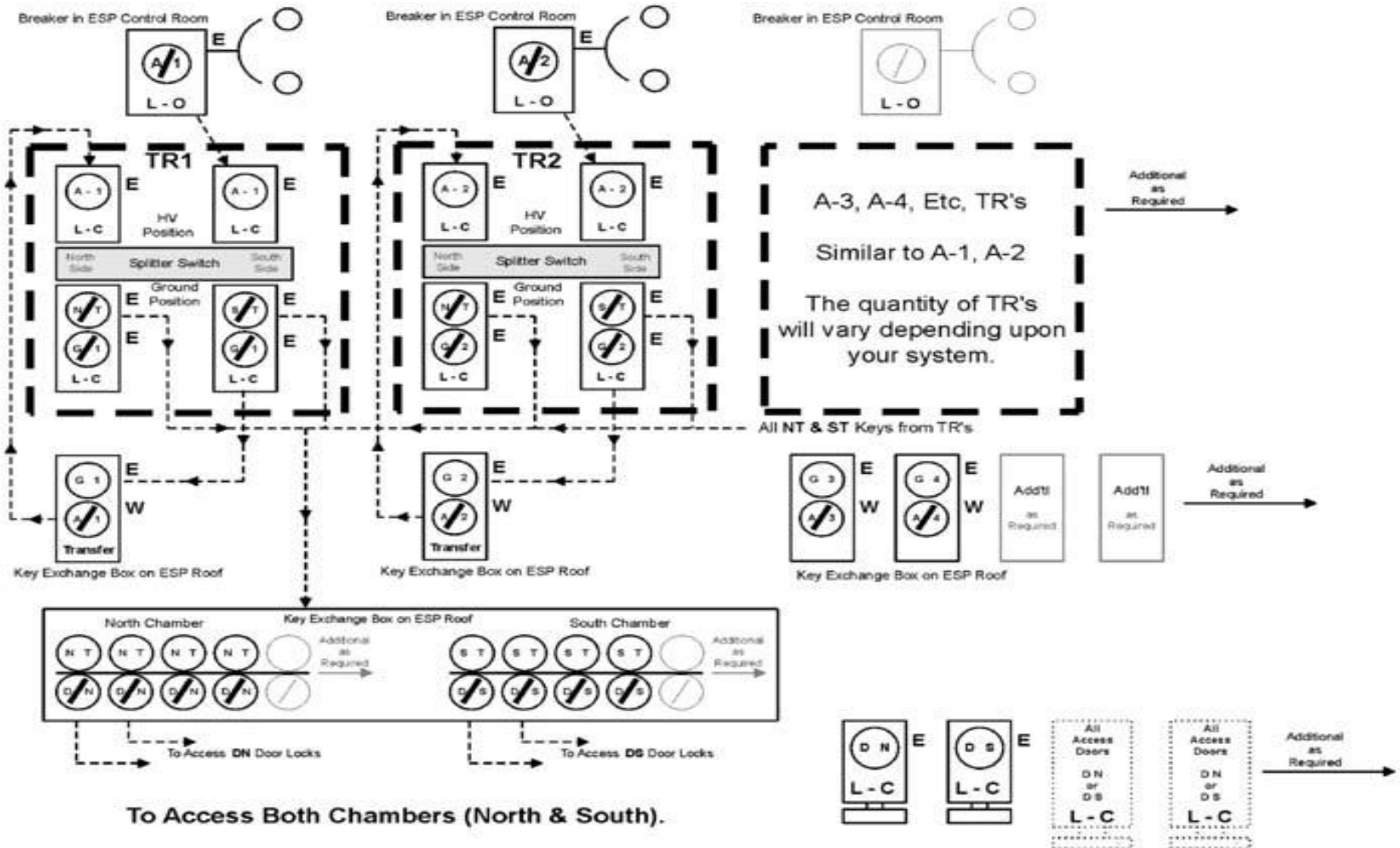

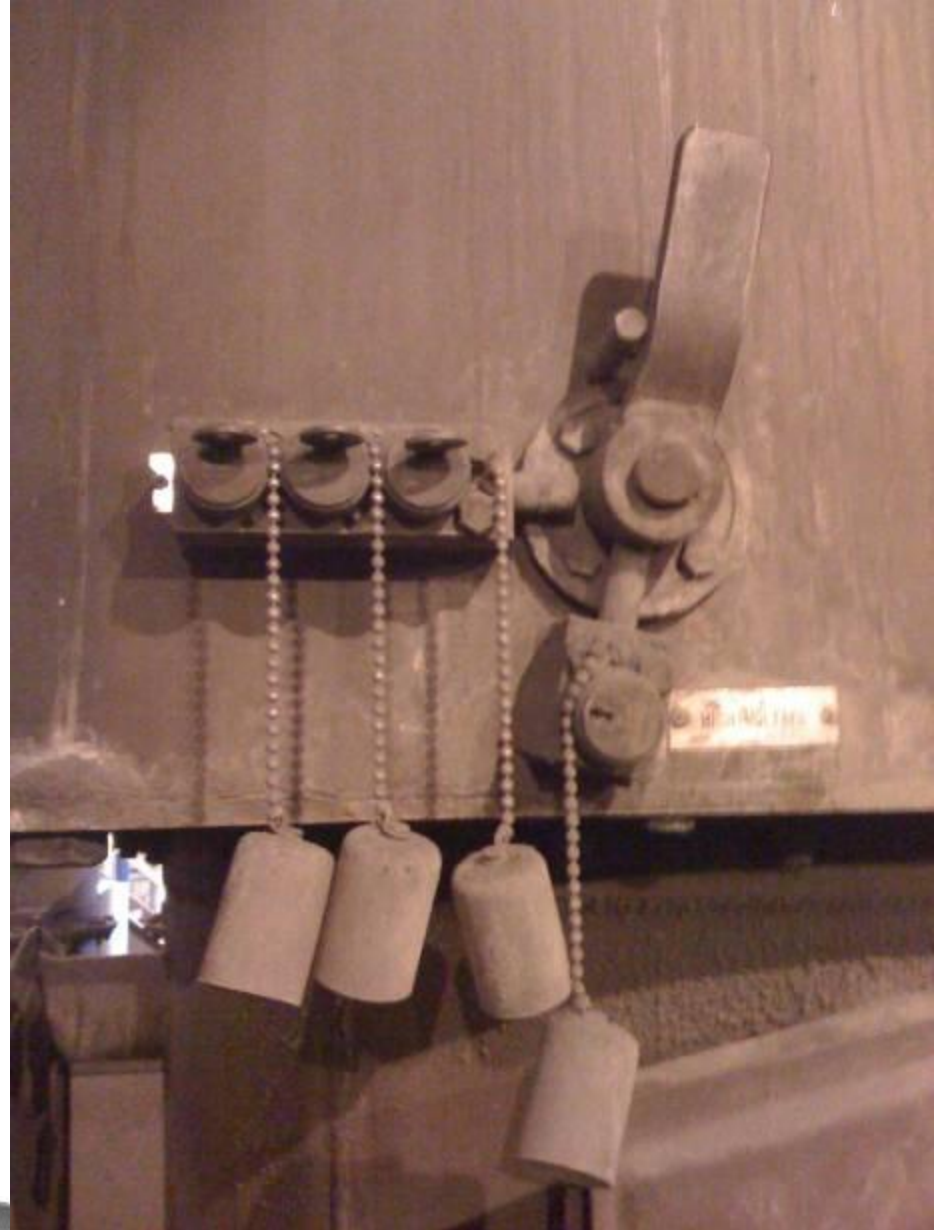

POP QUIZ

- LETS INTERLOCK AN ESP
 - 4 BREAKERS
 - 4 SINGLE BUSHING T/R SETS
 - 12 ACCESS DOORS



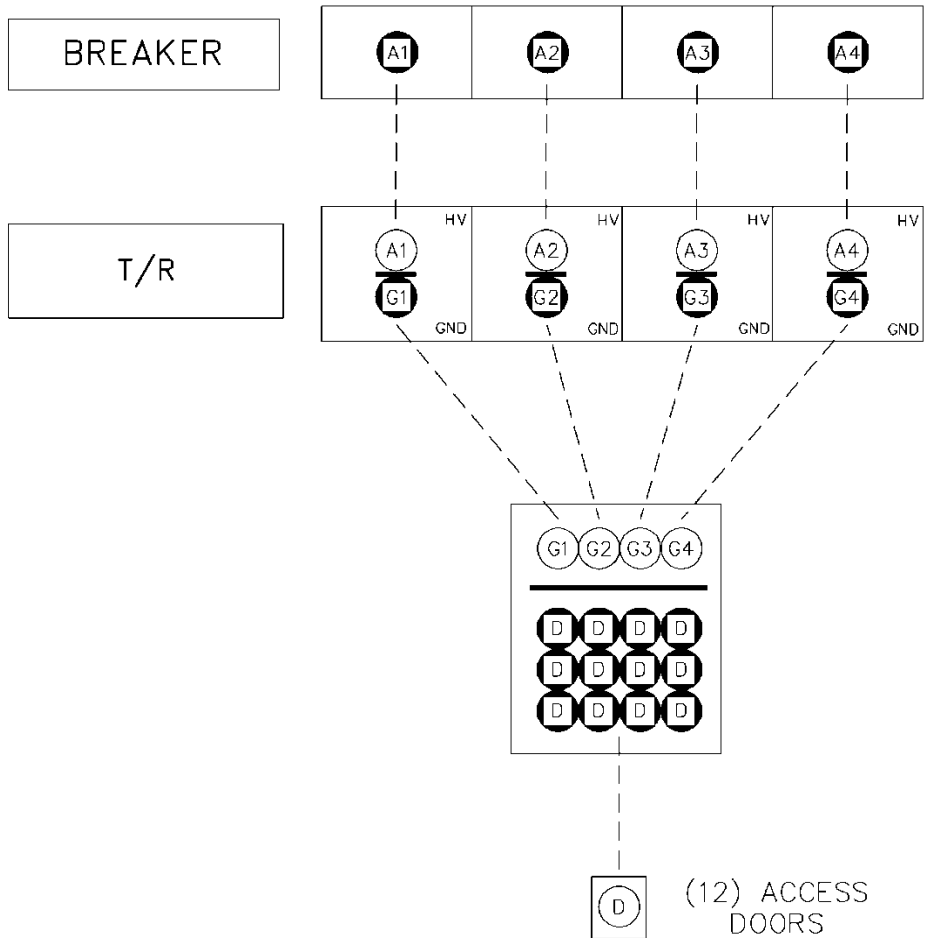

Questions and Answers

